



English

Installation, Operation and Maintenance Instructions

Borehole Pump

Contents

Contents	Page
Warranty	4
Introduction	5
Safety Notices	6
Borehole Systems	7
Overview	8
Equipment	9
Pre-installment Checks	11
Motorised Units	12
Pre-assembly	14
Installation	17
Installation Instructions for A Head Only	21
Installation Instructions for B and C Heads Only	24
Installations Instruction for DR Drive Head	26
Installations Instruction for RD-F30A Drive Head	29
Operating Instructions	31
Maintenance	32
APPENDIX 1	34

Warranty

Warranty

1. Pumps manufactured by Mono Pumps are covered by warranty for a period not exceeding twenty four (24) months from installation.
2. Mono Pumps will make good by repair, or at their option, the replacement of faulty parts under warranty, providing always that:
 - (a) The equipment was correctly installed and properly used in accordance with Mono Installation and Operation Instruction and accepted coeds of good engineering practice.
 - (b) The claim for goods under warranty arises solely from faulty design, material or workmanship.
 - (c) The repair is carried out in the Mono factory or by an authorised dealer or distributor appointed by Mono Pumps. Authorised agents must obtain written approval from Mono Pumps before completing any repairs under warranty.
 - (d) All freight costs to and from the factory or repair agent are to be paid by the purchaser.
3. In the case of equipment or components which are not of Mono manufacture, but supplied by them, the warranty is limited to that extended by the suppliers or manufacturers of such equipment.
4. Mono Pumps warranty does not cover any of the following:
 - (a) Claims for third party liability of damage caused by failure of any of the company's products.
 - (b) Damage caused by abnormal operating conditions, war, violence, storm cataclysm or any other force.
 - (c) Damage caused by the equipment being used for an application for which it is not recommended.
 - (d) Damage caused by sand or abrasive materials, corrosion due to acid waters, electrolytic action, liquid temperature beyond the recommended range, cavitation, improper supply voltage, use of non-approved control gear, inadequate cooling, or insufficient liquid to enable the pump to perform to specification.
5. The decision of Mono Pumps in relation to any claims or disputes over warranty is final.
6. The warranty is in lieu of all other warranties and conditions expressed or implied, written or oral, statutory or otherwise, which are hereby negated and excluded.
7. This express warranty does not exclude any conditions or warranty implied by the Trade Practices Act 1974 or separate State laws and in addition to any other right, that the original purchasers or any subsequent purchaser may have at law.

In case of claim please contact your Authorised Mono Dealer or contact Mono Pumps (Australia) Pty Ltd direct with details as completed in Delivery Record.

Introduction

The Mono Water Pumping System you have purchased represents a significant capital expenditure of quality, efficient equipment. Once the system is properly installed, and with minimal maintenance, you can expect a long and efficient trouble free service life.

EQUIPMENT DELIVERED

Your system will consist of one or more of the following items:

1. Drive and discharge head.
2. Pump Element.
3. Column and shafting.
4. Column to head kit.
5. Column to element kit.
6. Stabilizers.

Ancillary Equipment:

1. Engine/Electric motor.
2. Vee drive assembly.
3. Vee drive guard.
4. Base plate assembly.

Damage during delivery to any components should be reported promptly to an authorised Mono dealer or to the Mono Pumps office in your capital city.

Safety Notes



Guard or Belts and rotating components between drive head and motor. All guard must be in accordance with local regulations. The equipment must not be run without guarding in place.



Any electrical connections must be carried out by a qualified electrician in accordance with the local regulatory requirements



Fully isolate equipment prior to any maintenance.



All pumps must be bolted down to prevent them moving and causing injury or damage



All powered bare shaft units must be mounted on suitable bases and guarded to prevent injury or damage.



Hot Surfaces - During operation drive head may become hot.



Heavy Item - Always use suitably rated lifting equipment for installation and maintenance of the system.



It is recommended that a pressure relief valve be fitted to the discharge of the pump to prevent over-pressurisation of the system. The relief valve should be set at the minimum pressure rating of any component in the system.



Be careful to avoid any contamination of the bore with diesel fuel or other petroleum based products as damage may occur to the natural rubber based stator.

Borehole Systems

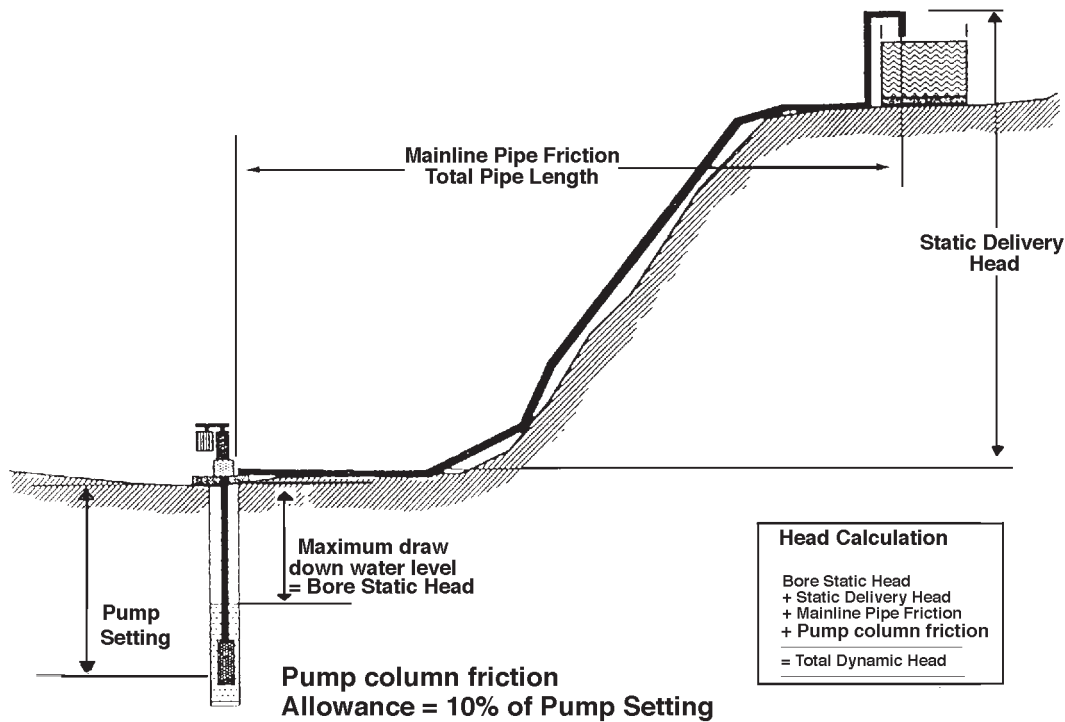

TOOLS REQUIRED

The Mono Borehole Water Pumping System is designed for easy installation with few specialised tools required, as follows:

- firm standing tripod of suitable load capacity which gives at least 4 1/2 metres clear lift
- a safety winch or block and tackle. An adequate length of wire rope of sufficient load rating to take the weight of column and shafting with swivelling safety hook, sling or lifting cables
- two pairs of pipe wrenches - (914mm/36")
- two pairs of vice grips
- one hacksaw
- one set of imperial and metric Allen keys
- lifting tool & column clamp
- wire brush and file

- thread sealant for column - stag
- thread lubricant for shafting - molybdenum grease Kopre Kote or Nickel Antisieze.
- basic set of ring and open spanners
- bucket and stop watch to measure flow
- pressure gauge to measure head.

SAFE WORKING LOADS MATRIX

Weights of Columns and Shafting (Kg. per metre)

<u>NB</u>	<u>DRY</u>	<u>INCLUDING WATER</u>
1 1/4" (32mm)	4.5	6.5
1 1/2" (40 mm)	5.5	7
2" (50mm)	8	10
2 1/2" (65 mm)	10	14
3" (80 mm)	13	18
4" (100 mm)	18	26

Overview

Average safe working loads for wire rope in reasonable condition would be:

6mm (1/4") dia.	600 kg per rope
10mm (3/8") dia.	1500 kg per rope
12mm (1/2") dia.	2500 kg per rope

Note: The maximum load a block and tackle may lift safely is the above figure x number of ropes attached to or going through the bottom sheaf.

Overview

Installing a borehole pump is not difficult provided you are well organised and that you have read these instructions before commencing the work. The following summary gives an overview of the installation procedure. Note that the preparatory work and pre-assembly steps are most important to achieve a smooth running job.

Summary of events:

- Checks prior to delivery of the system -
- Preparation of the work site -
- Check alignment of bore -
- Pre-assembly of all the drive shaft lengths -
- Pre-assembly of all the column and shafting -
- Installing the base plate -
- Lowering the pump element into the bore -
- Lowering the column and shafting into the bore-
- Finishing column and shafting installation -
- Installing the pump head and driver -
- Final actions -

Each of the above steps will now be discussed in detail.

Equipment Items

What you should receive:

1. A Pump Element

Depending on the system duty (i.e. required flow and total head).

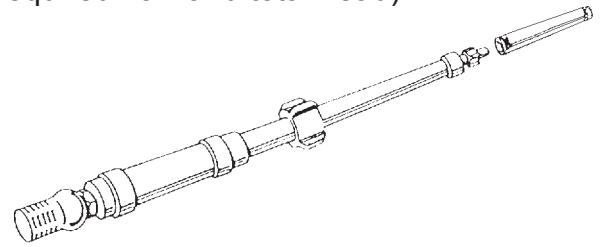

2. Drive and Discharge Head.

Depending on the application Drive and Discharge Head assembly is supplied bareshaft or fitted with electric motor or engine drive, driven by either a 1/4 twist belt drive assembly or a right angle drive.

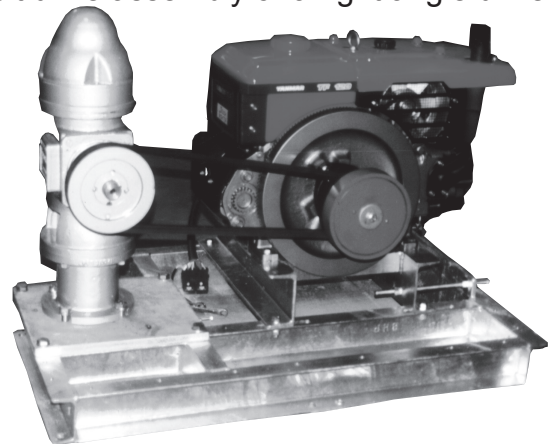

3. Column and Shafting

There should be sufficient lengths of column and shafting to reach the level of pump setting in the bore.

The Rising Main (column assembly) comprises:

For each length of column (3m/10ft) there are two lengths of drive shaft (1.5m/5ft) and two bobbin bearing shaft assemblies.

Equipment

The column is made of heavy duty galvanised pipe, with parallel thread. Each pipe length is supplied with a pipe socket fitted on one end. The drive shaft is made from high tensile steel as standard (stainless steel optional).

The Bobbin Assembly comprises:

- 2 bobbin bearing shafts of high tensile steel (stainless steel optional)
- 4 coupling nuts of high tensile steel (stainless steel optional)
- 2 bobbin bearings, natural rubber.

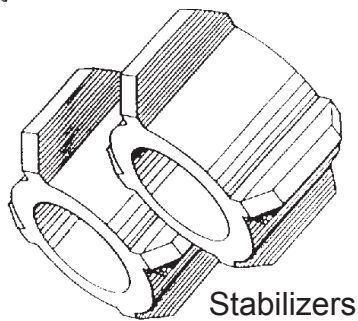
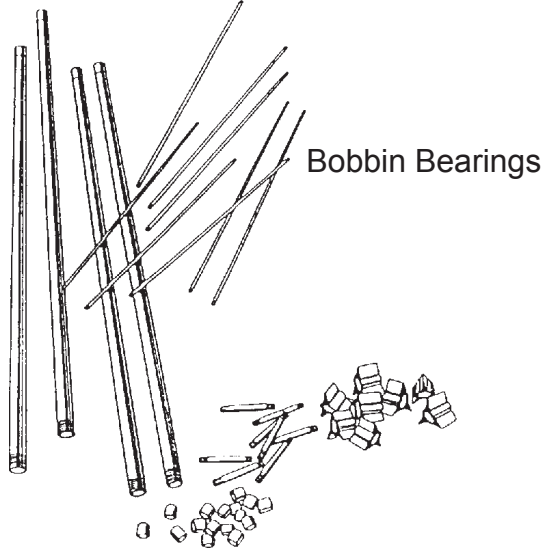

4. Stabilisers

Natural rubber stabilisers are used in cased bores, one every third length of column. In un-cased bores at least one stabiliser should be used per each length of column.

- (a) Trimming and fitting column stabilisers. Mostly these should fit without the need for trimming. However if needed, use a hacksaw or sharp knife to trim them so they fit snugly and centrally in the bore casing. A chamfer top and bottom on parallel types will help installation (see sketch). Wetting the saw or knife with water makes this job much easier.

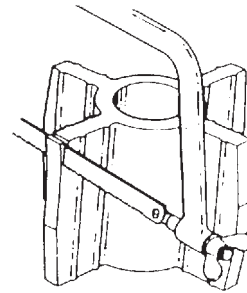

- (b) 2 stabilisers are fitted to the pump element. They may also need trimming.

5. Final Connecting Shaft and Jack Coupling

- (a) A Mk 1 Vertical Drive Head. The final connecting shaft is 279mm/11" long x 1/2" diameter and is stainless steel. The jack coupling comes with internal thread to accept the drive head main shaft with 4 grub screws on the end. There is a horizontal hole in the centre to allow adjustment and tightening using a bar placed through the hole.

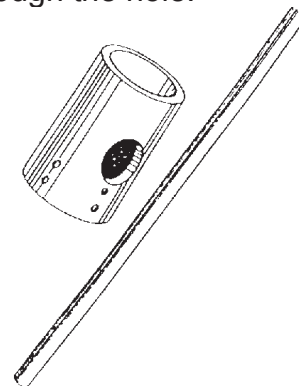

Equipment

(b) B Mk2, B MK3 and C MK3 Vertical Drive Heads.

The B MK2 and 3 heads use a 3/4" x 2' shaft. The C MK3 heads use a 7/8" x 3' shaft.

(c) DR21 and RD F30A Right Angle Drive Heads.

The DR21 head uses a 20mm x 600m shaft with a 3/4" thread at one end. The RD F30A head uses a standard 7/8" x 3' shaft, with a 7/8" thread at one end.

6. Lifting and Lowering Tool

This tool screws into the column socket enabling the column to be safely lowered into the bore. The eye of the lifting tool is provided for the hook from the block and tackle on the tripod.

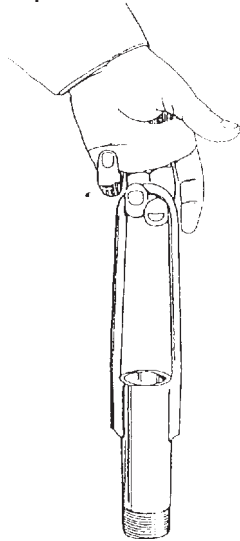

7. Column Clamp

This tool must be used whenever lowering or raising any equipment into the bore. It holds the column in position and must always be fitted below the column socket as a safety precaution.

For most efficient installation, you are advised to use a Morissey, or similar, Pipe Column Clamp but if this is not available an effective substitute can be improvised by sawing vertically through a Column Socket, and welding to each half, two 80 x 10 mm mild steel side "wings", as illustrated. The width across the wings should be 1 1/2 times the diameter of your bore casing, (e.g., if your bore casing is 200 mm diameter, the width across the wings should be 300 mm). Drill holes as illustrated to take M12 diameter bolts and your clamp is complete.

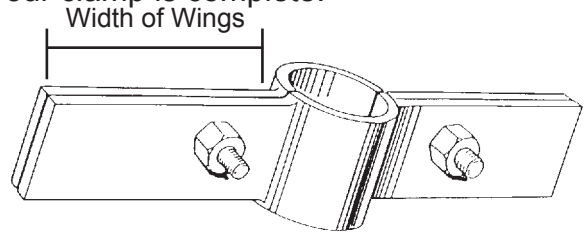

8. Base Plate

The drive and discharge head is fitted to a base plate. Rag bolts, nuts and washers are supplied, for bolting the base plate to the concrete plinth.

The base plate is bolted onto a concrete plinth which is usually prepared in advance to allow the concrete time to cure. Refer to the drawings supplied with this manual and next section on preparing the plinth.

Pre-Installment Checks

Checks Prior to Delivery of the system

(1) Check to see if the bore is cased.

If it is not cased, more stabilisers on the column will need to be used. These will have to be ordered with the equipment.

(2) Measure the diameter of the bore casing.

The stabilisers normally are trimmed to fit the bore casing size. If the casing is larger than normal or the pump is to be installed in a well, Mono will need to be consulted to allow for the special requirements of this situation.

(3) Check the depth of the bore.

Method: Place a weighted object on end of a rope and lower into bore. When the rope goes slack the bottom of the bore has been reached. Measure the length of rope used to the point where the rope went slack.

(4) Check the water level.

Method: Use the weighted object on the end of a rope as before. Either listen for the splash or locate the wet mark on the rope after the weighted object reaches the bottom of the bore.

(5) Check the alignment of the bore.

Normally this should not be necessary to check since most bores if drilled properly will be straight. However if the bore is suspect, use the following method to determine if the bore is suitable for installing the pump.

Lower **3 column lengths**, joined together (with a socket at the bottom end to avoid thread damage) but without stabilizers down the bore to the pump setting. You will need the bore depth of cable or rope to do this. If the column lengths reach the desired setting without any resistance then the pump can be installed. If the column lengths meet resistance or jam then the pump should not be installed. Consult your Mono dealer for advice. Failure to observe this recommendation may result

in premature wear and possible damage of the pump and lineshaft components.

(6) Determine the pump setting.

Normally the pump is positioned about 3m/10ft above the bottom of the bore or just above the screen. The pump setting depends on the normal draw down of the water level which is expected from a heavy pumping duty. The pump should be positioned to avoid dry running even under the worst possible conditions.

The draw down level of the bore is usually written on the driller's certificate.

If there is some doubt about the test results or the condition of the bore is uncertain, it is recommended that the bore be tested prior to determining the pump setting.

This is achieved by bringing an engine or electric driven pump to the bore and pumping at a higher than required rate for at least 24 hours. The level of the water in the bore is then re-measured and the pump setting decided.

Example - The standing water level may be 6m/20ft from the surface. When the bore is pumped for 24 hours at required flow rate, the draw down water level may hold at 12m/40ft. Therefore it would be safe to install the pump at below 12m/40 ft, say 14m/45 ft.

(7) Prepare the Plinth

Drawings of the plinth size and construction for both electric and diesel drive bore hole pump types are shown on the following pages.

There are two ways of attaching the base plate of the pump to the concrete plinth.

(a) Place rag bolts into wet concrete immediately after pouring as per the drawing dimensions.

(b) After the concrete plinth has cured, holes may be drilled into the concrete and Loxins used to hold down the baseplate onto the plinth.

A,B & C Heads Motorised Units

Dimensions in Metric (mm) top. Imperial equivalent (inches) below.								
Drive Head	A	E	F	G	H	L	L ₁	R
AMK1 Pad Mount Motor on Base	500 19.7	400 15.7	400 15.7	- -	167 6.6	1 1/2" BSP	1 1/2" BSP	530 20.9
BMK2 Pad Mount Motor on Base	820 32.3	320 12.6	300 11.8	- -	198 7.8	2 1/2" BSP	2 1/2" BSP	750 29.5
BMK3 on Tee Base Motor on Base	820 32.3	1000 39.4	500 19.7	160 6.3	198 7.8	2 1/2" BSP	2 1/2" BSP	850 33.5
CMK3 on Tee Base Motor on Base	935 36.8	1000 39.4	500 19.7	160 6.3	210 8.3	4" BSP	4" BSP	900 35.4

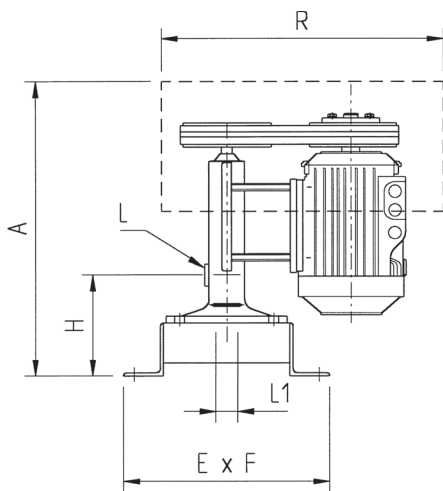

AMK1

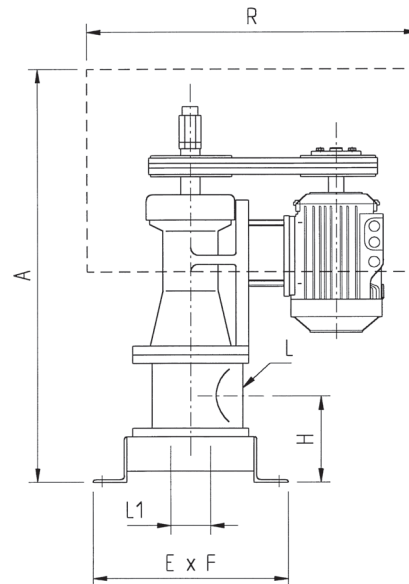

BMK2

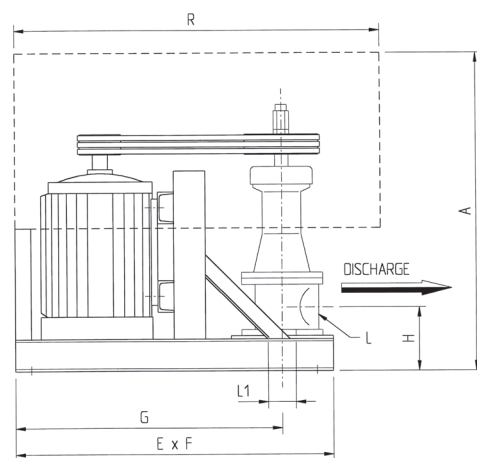

BMK3 & CMK3

NOTES:

- 1 - Concrete mounting plinth for normal soil conditions should be poured using 4:2:1 mix (screenings:sand:cement) and left to cure for at least 48 hours before fixing baseplate.
- 2 - Length and width of the plinth to be equal to the baseplate plan dimensions + 100mm minimum, all round. Depth to be minimum 200mm below ground level. The finished top surface must be square with the bore.
- 3 - It is important for correct operation of the pump that the vertical centreline of the drive head is in line with the bore centreline.

DR & RD F30A Heads Motorised Units

Motorised Right Angle Drive Head - Diesel Engine

	Dimensions in Metric (mm) top.				Imperial equivalent (inches) below.			
Drive Head	A	E	F	G	H	J	L	L ₁
DR21 Std. Vee-Belt Drive	788	1200	900	260	214	351	2 1/2"	2 1/2"
Kubota & Yanmar	31.0	47.2	35.4	10.2	8.4	13.8	BSP	BSP
RD F30A Std. Vee-Belt Drive	783	1200	900	250	206	485	4"	4"
Kubota & Yanmar	30.8	47.2	35.4	9.8	8.1	19.1	BSP	BSP

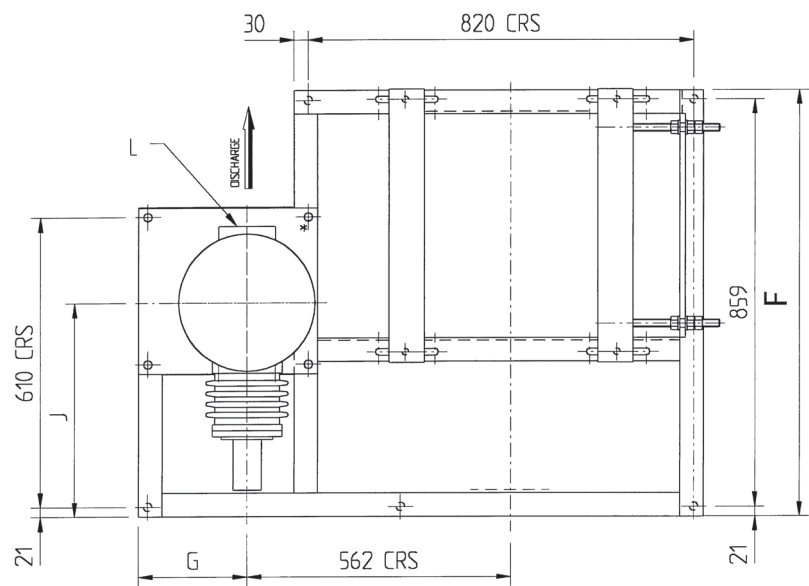

NOTES:

- 1 - Concrete mounting plinth for normal soil conditions should be poured using 4:2:1 mix (screenings:sand:cement) and left to cure for at least 48 hours before fixing baseplate.
- 2 - Length and width of the plinth to be equal to the baseplate plan dimensions + 100mm minimum, all round. Depth to be minimum 200mm below ground level. The finished top surface must be square with the bore.
- 3 - It is important for correct operation of the pump that the vertical centreline of the drive head is in line with the bore centreline.

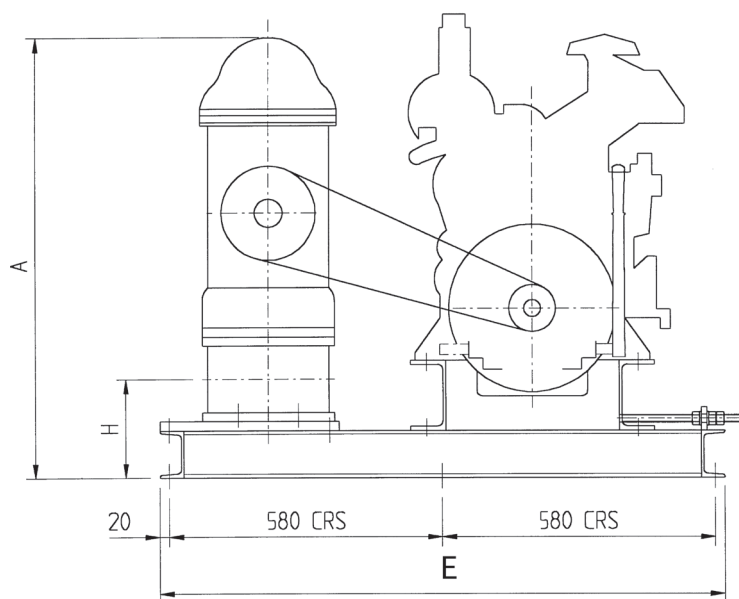

Pre-assembly

Preparation Of the Work Site

Ensure the work area is clean and clear. Position the tripod with the apex centrally above the bore. Test the tripod carefully to ensure steadiness, firmness and rigidity. Ensure that the feet of the tripod are fixed or secured, so that they will not move during lifting.

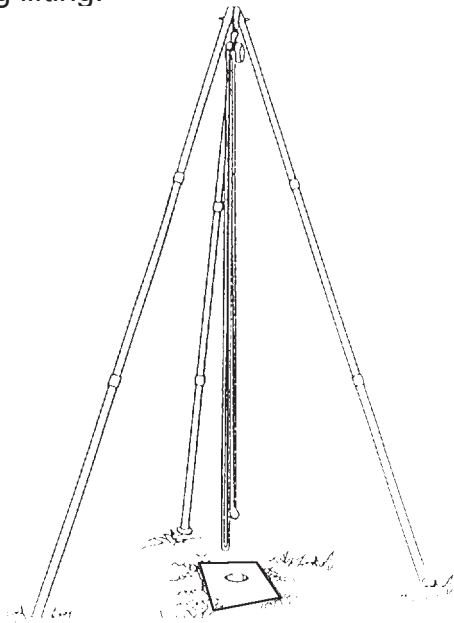

Pre-Assembly of the Drive Shaft Lengths.

In a dirt free area, preferably on blocks of wood, assemble the drive shafting. Each assembly comprises 2 drive shafts and two bobbin bearing shafts, 4 coupling nuts and two bobbin bearings, in 3m/10ft lengths.

Steps

- (1) Take one long drive shaft and place in the working area. Do not grease inside of female threads as build up between shaft ends will cause hydraulic effect.

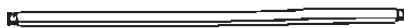

- (2) Assemble from right to left. Lubricate male shaft threads only with small amount of Kopre kote antisieze.

- (3) Screw a coupling nut onto the left hand end leaving two threads exposed. Note: Threads are left hand.

Only use vice grips on long drive shaft and coupling nuts.



WARNING: Never use vice grips on the bobbin bearing shaft. The vice grips could score the bobbin shaft and as it rotates inside the captive bobbin bearing, the scoring could grab or cut the bobbin bearing.

- (4) Screw the bobbin bearing shaft into coupling nut, after lubricating male thread only.



- (5) Place the bobbin bearing on the bobbin bearing shaft arrow pointing left. Note: An arrow and top is marked on the bobbin bearing. The arrow must be pointing upwards when the shafting is placed into the column in the bore.



- (6) Screw on another coupling nut.
- (7) Place vice grips on the drive shaft and first coupling nut.
- (8) Tighten this sub assembly.



Pre-assembly

Steps

- (9) Screw second long drive shaft into left hand coupling nut leaving two threads exposed.



- (10) Place vice grips on second coupling nut and second drive shaft. Tighten. Screw on coupling nut leaving two threads exposed.



- (11) Screw in bobbin bearing shaft.



- (12) Place bobbin bearing on shaft.

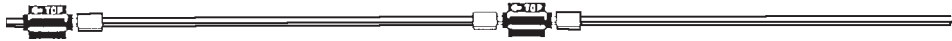

- (13) Screw the fourth coupling nut down by hand leaving two threads exposed. This will be tightened when joining next shaft assembly.

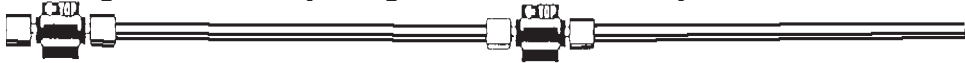

- (14) Place vice grips on third coupling nut and second drive shaft. Tighten. The assembly is complete.

NOTE: Two threads are left exposed to ensure that the shafts on either side are screwed evenly into the coupling nuts. This will also ensure that mating shafts bottom out and lock against each other, allowing free travel of shafting inside the bobbin bearing. Continue assembling shafting until all the 3m/10 ft shafting assemblies are completed.

Pre-assembly

Pre-Assembly of all the Column and Shafting

The number of 3m/10 ft shafting assemblies prepared should match the number of 3m/10 ft columns provided for the bore setting.

NOTE: Each length of column section comes complete with a socket screwed to one end.

Steps

- (1) Line up the columns.
- (2) Pick up a shafting assembly.
- (3) Fit the left hand end (end with the coupling nut on it) of the shafting into the male threaded end of the column.
- (4) Push the shafting assembly into the column leaving 150mm/6 inches of drive shafting protruding from the threaded end of the column.

Note that the arrow on the bobbin bearing points towards the socket.

- (5) Fit stabilisers to the column.

- (6) Stabilisers may need to be trimmed to suit the bore casing diameter.

Remember to measure accurately.

"Measure twice and cut once."

Repeat for all the lengths of column.

NOTE: Installation of the pump can be achieved with the head base in position over the bore.

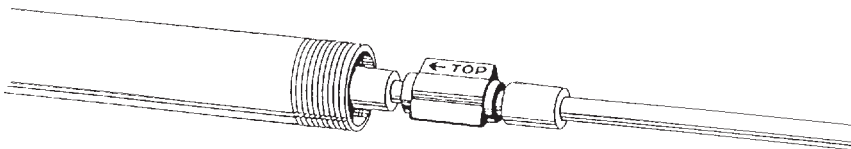

Stabilisers should be fitted to every third length of column. One on the first length of column and then every third length. It is recommended that a stabiliser is fitted to the first and last length of column in addition to the intermediate lengths.

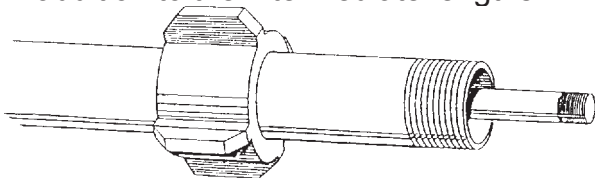

Installation

Installing the Base Plate

Place the base plate on the concrete plinth place nuts on the rag bolts or fit the Loxins and bolt down.

Baseplate Frame Complete with Drive Head and Prime Mover.

In most cases the baseplate frame will be supplied complete with the drive head fixed in position and connected to the prime mover (diesel or electric motor) via belts and pulleys.

Prior to the installation of this baseplate, the drive head will need to be removed.

The installation of this baseplate arrangement is as follows:

- (1) Remove drive guard if fitted.
- (2) Loosen the prime mover baseplate /packer hold down bolts, and slide the prime mover towards the drive head to loosen the belts.
- (3) Remove the belts, and slide the prime mover as far away from the drive head as possible.
- (4) Remove the drive head hold down nuts and bolts.
- (5) Remove the drive head from the baseplate.
- (6) Remove the drive head plate from the drive head/prime mover baseplate frame. (DR21 and RD F30A right angle drive arrangements).

Lowering the Pump Element into the Bore

Steps

- (1) Screw the lifting tool onto the socket on the end of the pump barrel.
- (2) Place the column clamp on the barrel of the pump below the socket. Tighten the clamp.

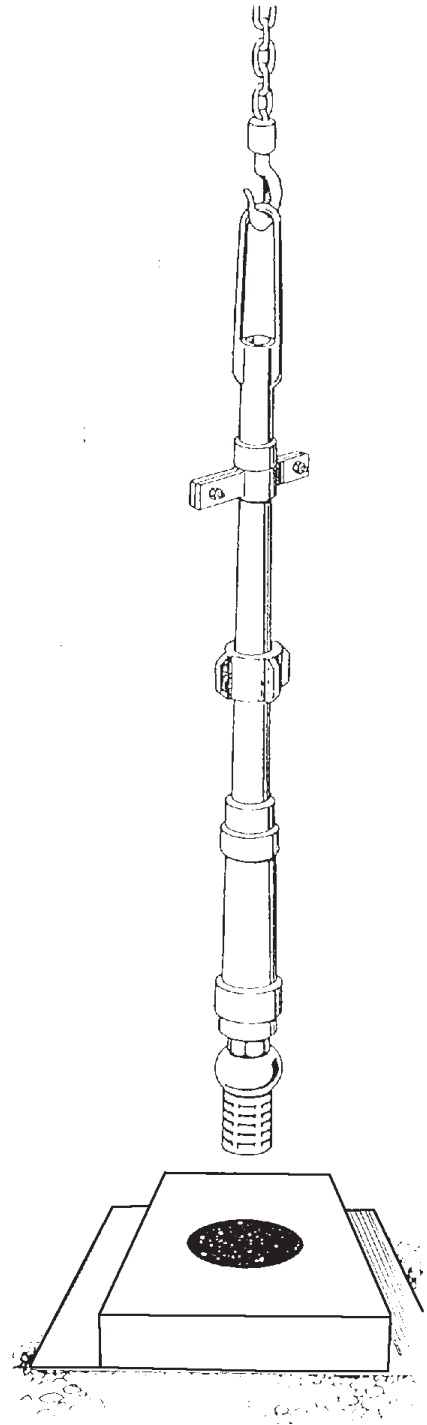

Installation

- (3) Bring the hook from the block and tackle to the lifting tool and lift the pump above the bore ensuring that the pump is central to the bore hole.
- (4) Lower the element into the hole until the bore clamp rests on the base plate.
- (5) Remove the eye hook and lifting piece.
- (6) Unscrew the lifting tool from the element and screw it into the first length of column. The lifting tool will screw into the socket on the end of the next length of column. (The other end of the column is left with the thread exposed).
- (7) Screw the long coupling onto the shaft protruding from the element. (The long coupling is supplied in element to column connection kit - Refer to Appendix 1 for the correct kit).

Lowering the Column and Shafting into the Bore

Steps

- (1) Lift the first column assembly above the bore. It may be necessary to hold the shafting to stop it from slipping out of the column.

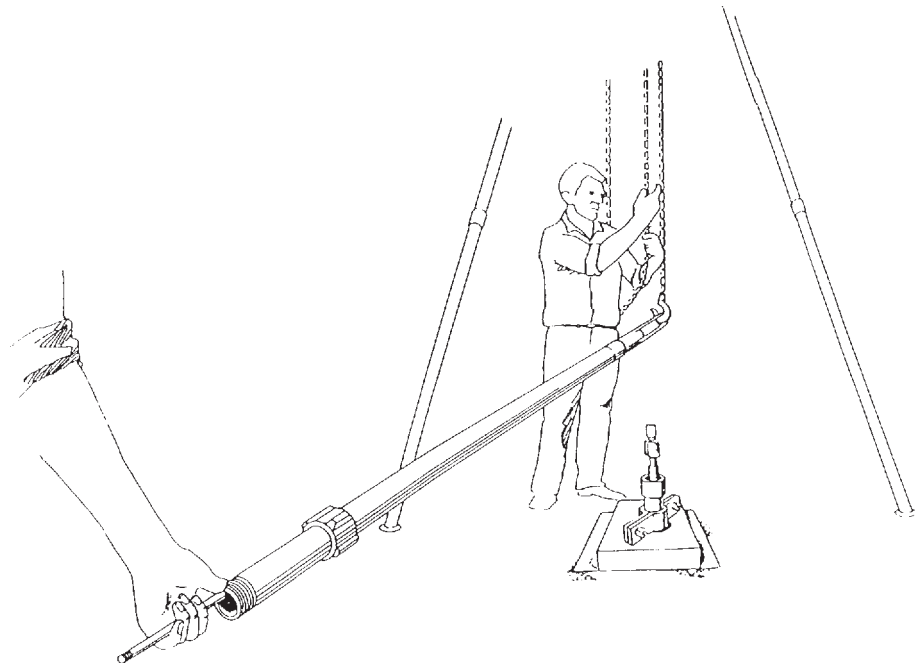

Installation

- (2) Put anti-seize compound (Kopre Kote) on the drive shaft male thread. Use sparingly. If not, a cushion effect may occur preventing shafts from properly butting together. There should be a male drive shaft protruding from the lower end of the column assembly and a long coupling female thread protruding from the pump element.
- (3) Pull down the shafting, and using two pairs of vice grips, screw the shafting into the long coupling.

NOTE: The threads are left handed. Tighten, using one vice grip on the long coupling and one on the drive shaft.

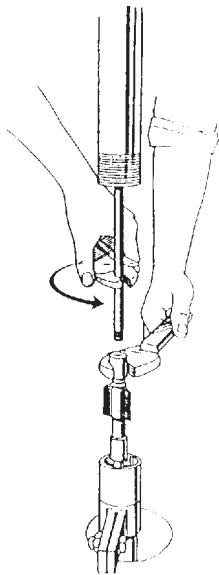

- (4) Put thread sealant (Loctite 567) on the exposed threads of the column. Lower the column down to meet the socket on the end of the pump. Tighten with the pipe wrench. Columns must butt together inside the socket.



NOTE 1: To achieve maximum strength and best sealing, each male thread must be screwed equally into the socket. This may leave two threads exposed on each male column.

NOTE 2: All shaft threads must be coated with anti-seize compound (Kopre Kote) and all column threads must be coated with a pipe jointing compound (Loctite 567). Kopre Kote prevents thread seizure and corrosion. Loctite 567 is a column sealant and anti corrosion agent. In the unlikely event that the pump has to be lifted out of the bore at a later date, use of these two substances will allow easy and trouble free disassembly.

- (5) Lift the whole pump and column assembly clear of the base frame, making sure that the block and tackle is taking the weight of the column, shafting and pump element. Remove the column clamp from the element and gently lower the assembly down the bore, leaving approximately 250mm (10 inches) of column exposed.

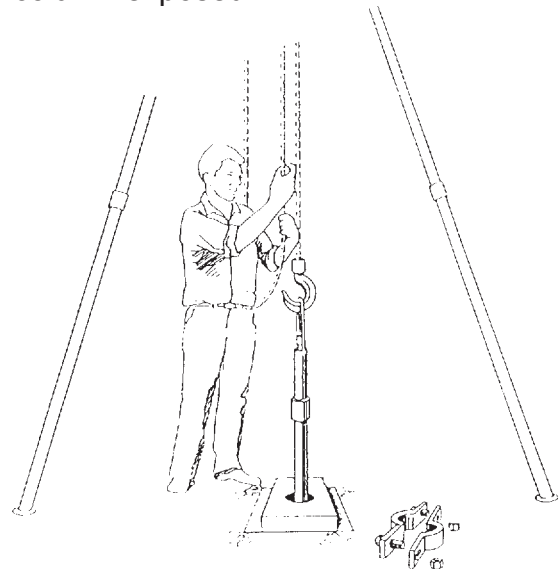

Installation

- (6) Refit the column clamp below the upper most column socket and tighten the clamp to the column. Lower the pump and column until the clamp is resting on the baseplate. Release the block and tackle.

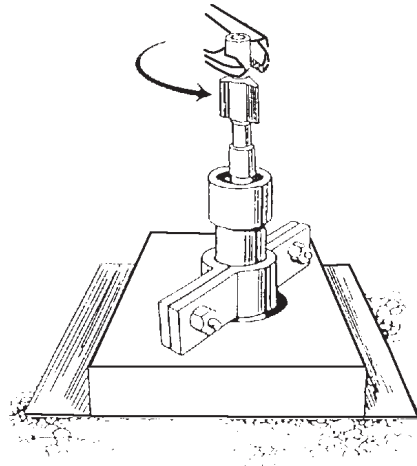
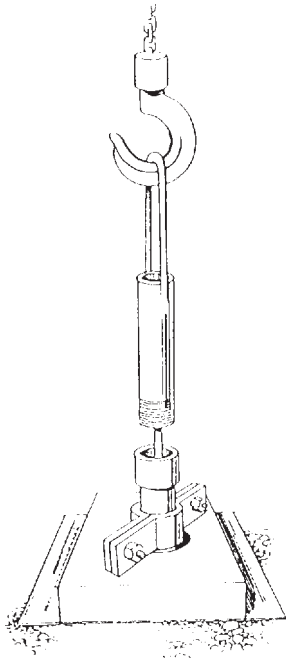

The short piece of column is used last. This piece enables easier connection of the drive head due to having the end of the column closer to the ground. The final column assembly is shown below.



WARNING: When screwing column down in a clockwise direction (column has right hand thread), as shafting is left hand or anti clockwise, shafting may unscrew.

- (7) In case the shaftings may have been loosened when the column was tightened, when the next length of column and shafting is being connected, take the vice grip and place it on the coupling nut protruding from the column and rotate it in an anti-clockwise direction. The shaftings should then be properly tightened.

Repeat the column and shafting installation procedure until all the lengths have been fitted.

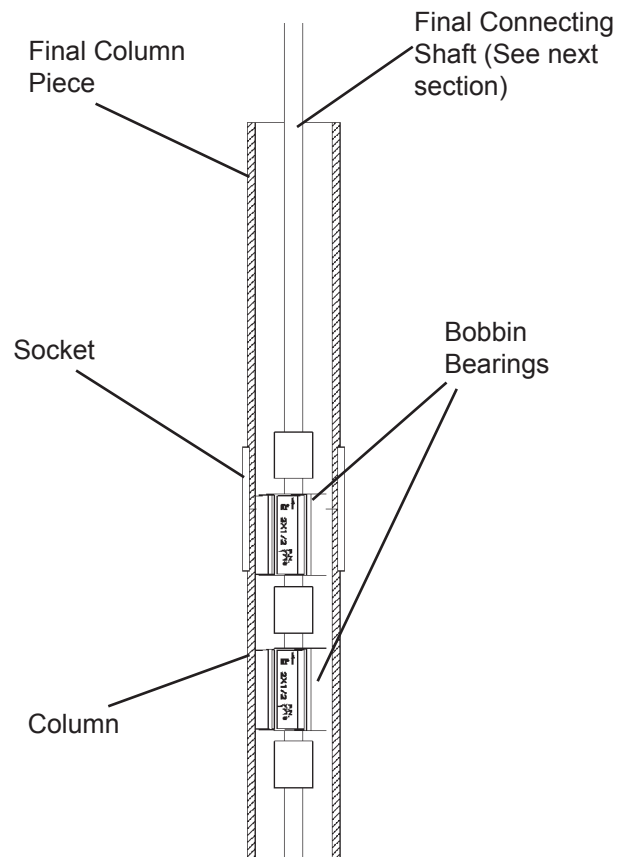

Installation A Head only

Installation: A Head Assembly

Final Column and Shafting Installation

Steps

- (1) After installing all the necessary column and shaft lengths, screw in the final 1/2" X 9" connecting shaft into the last coupling nut. (Refer to Appendix 1 for the correct, final connection kit). Some shafting will be protruding. Take a block of soft wood and gently tap the top of the shafting to knock it down. This will ensure that the pump rotor has bottomed and is located on the datum bar of the pump element.
- (2) Measure from the top of the male thread of the column section 55mm along the protruding shaft. Mark the point.

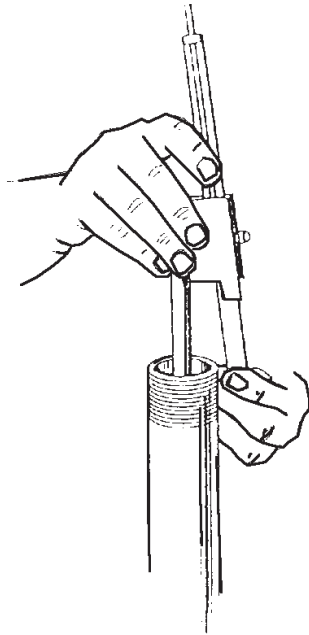

Remember to measure accurately.

"Measure twice and cut once."

- (3) Place a rag around the shafting covering the opening at the end of the column.
- (4) Using a hack saw cut off the final connecting shaft at the mark.
- (5) Using a small fine file, dress up the end of the shaft, to remove burrs.

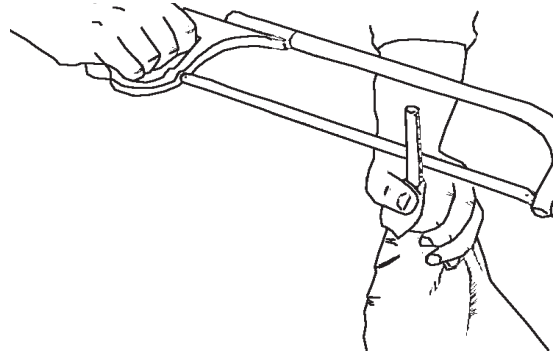

Installing the Pump Head

Steps

- (1) Take the jack coupling and place the plain end on the shafting and tap it down until the end of the drive shaft just comes up to the bottom of the hole through the centre of the jack coupling.
- (2) Tighten each of the socket set screws in the jack coupling onto the shaft to make a mark.

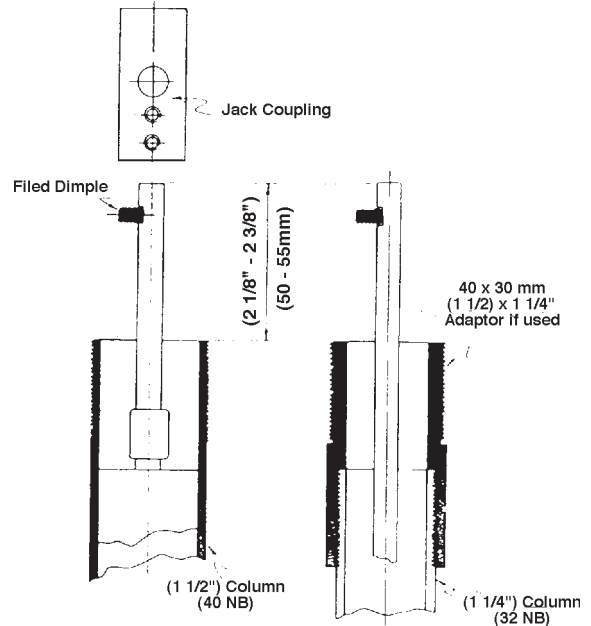

- (3) Loosen and remove the jack coupling.
- (4) Using the marks as a guide, file flats on the shaft to allow for the seating of the socket set screws when fitted.
- (5) Re-fit the jack coupling.
- (6) Line up the socket set screw holes with the flats on the shaft. Tighten the socket set screws onto the flats.

Installation

A Head only

A Head Final Connection

Steps

- (1) Take the drive head and remove the inspection cover.
- (2) Apply thread sealant to column and screw the head down on the final column until the main shaft comes into contact with the jack coupling. This can be observed through the inspection opening.
- (3) Ensure that the vee belts have been removed from the drive head pulley.
- (4) Place a bar or large screw driver through the inspection cover and the hole in the jack coupling so that the jack coupling is prevented from turning. Whilst screwing down the head onto the column, turn the drive head main shaft in an anti-clockwise direction and start the main shaft screwing into the jack coupling.

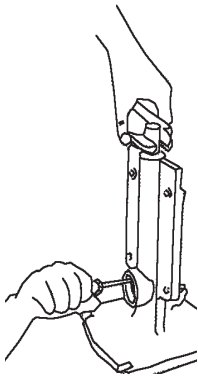

- (5) Turn the pulley by hand in an anti-clockwise direction whilst holding the bar through the jack coupling hole. This will now finally tighten the main shaft into the jack coupling.

NOTE: It is this final tightening of the head main shaft onto the jack coupling that effectively lifts the pump rotor off the datum plate. Provided the correct cut off and fitting procedures have been adhered to, the clearance will be 20-25mm.

- (6) Replace the inspection cover, ensuring that its gasket is in place. Tighten the bolts.

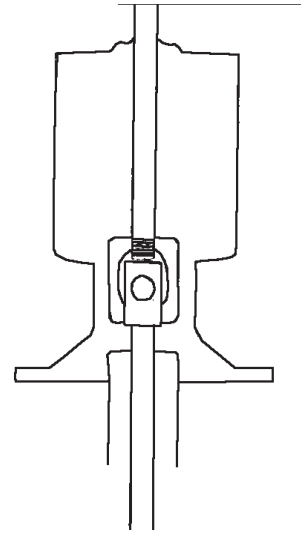

- (7) With the weight of the head and column and shafting taken by the block and tackle, remove the column clamp.
- (8) Lower the pump head to its final working position on the base plate. Install and tighten the hold down nuts and bolts.
- (9) Rotate the pump by hand by turning the pulley in an anti-clockwise direction. The pump should turn quite easily with no pronounced resistance.

Installation

A Head only

Final Actions

- (1) With the vee-belts disconnected, start and run the prime mover/driver and check that the pump rotation will be correct when the belts are reconnected. The 'A' vertical drive head shaft rotates anti-clockwise looking on shaft end.
Note: For electric drives ensure that the motor is wired in accordance with relevant local standards.
- (2) Replace vee-belts and check that the pulleys are aligned and the correct tension has been applied before finally tightening the prime mover/driver holding down bolts.
- (3) Refit the all-weather/safety cover.



Special Warning for Deep Bore Settings:
In deep setting bores, it may be that resistance is felt when the pump is turned by hand. This can occur, because the bobbin bearings are a snug fit into the column and are held captive in the column with the shaft rotating inside the bearing. During installation, when pulling and screwing the column down, the bobbin bearings can be forced up against the coupling nuts causing friction. This will normally not be evident in shallow pump settings.

If this is the case, the friction effect can be minimised by the following steps.

Steps

- (1) With the shafting completely attached, unscrew the discharge head assembly from the column pipe two complete turns.
- (2) Screw the head down again tightly and check the resistance by turning the pulley anti-clockwise.

- (3) If resistance is still felt, it may be necessary to repeat the above unscrewing the head, four turns and then maybe six turns. This should solve the problem.

NOTE: This procedure will ensure that the whole shafting assembly and the bobbin bearings are lifted and when the head is screwed back down, the bobbin bearings will be located in a central position along the bobbin bearing shaft, thus minimising the friction.

Installation

B and C Heads

Installation Instructions B and C Head Only

NOTE: The last length of 10 foot column and shafting will only require one bobbin bearing assembly, the final connecting shaft should screw directly into a coupling nut fitted to the last 5' shaft length.

Final Column and Shafting Installation (with element, column and shaft still held by column clamp).

Steps

- (1) After installing all the necessary column and shaft lengths, tightly screw the final connecting shaft into the last coupling nut.
- (2) With shafting protruding, take a block of wood and gently tap the top of the shaft to knock it down. This will ensure the pump rotor has bottomed and is located on the datum bar of the pump element.
- (3) Take the "B" or "C" head and remove the jack and lock nuts from the shaft. Separate the top and bottom sections of the head by removing the four bolts and nuts.
- (4) Screw on the column/head adaptor fitting to the column, then take the stuffing box section and tightly screw it onto the column head adaptor. (Refer to appendix 1 for the correct, final connection kit).
- (5) At this point you can now conveniently pack the gland with the packing supplied.

NOTE:

- (a) Ensure that each join of the gland packing piece is evenly offset approximately 1/2 turn from the next one.
- (b) Use the gland follower to press each piece of packing into the gland.
- (c) When gland packing is (4mm approx) from the top, place the gland follower plate in position and screw on nuts finger tight.
- (d) The gland follower can be tightened after pump has run. The nuts should then be tightened firmly to allow for a slight weep. Excessive tightening causes shaft

wear and excessive friction load on the prime mover/driver.

- (e) Place the rubber thrower onto the shaft.
- (6) Take the top section of the head and -
 - (a) Install over final connecting shaft. The final connecting shaft should now protrude at least 50-100mm above head mainshaft.
 - (b) Replace the four bolts and nuts, and secure top and bottom head sections together, tighten bolts and nuts securely.
- (7) Attach -
 - (a) Cable or chain from block and tackle to lifting lugs on the head.
 - (b) Taking the weight of complete pump assembly on lifting gear, raise sufficiently to remove the column clamp.
 - (c) Lower the complete assembly into place and secure the head onto the base plate with the bolts and nuts provided.
- (8) Install pulley on the main shaft and align at correct height to drive pulley.
- (9) Replace the lock nut and jack nut onto main shaft, screw both down as far as possible.
- (10) To ensure rotor is sitting on the datum point, again take a block of wood or soft mallet and tap the final connection shaft firmly.
- (11) Proceed to -
 - (a) Tighten grub screws in jack nut firmly to make position marks on the final connecting shaft.
 - (b) Loosen off grub screws and remove jack nut.
 - (c) File flats on shaft where grub screws have left marks. (Alternatively drill locating dimples) large enough to allow grub screws to seat.
 - (d) Replace the jack nut and securely tighten grub screws into flats. Take care with alignment of all 4 screws.

Installation B and C Heads

(12)

- (a) Holding the lock nut securely with a spanner, rotate the jack nut with another spanner in an anti-clockwise direction until the gap between jack nut and lock nut matches the shaft lift required, see the table below.

Shaft lifts (mm) required for BMk2, 3 and DR Heads to give the correct operating position of the rotor within the stator.

Pump Element	Depth of setting only - metres			
	0-60	60-120	120-180	180-240
310	10-15	OBSOLETE - INFO ONLY		
320	10-15	15-20		
420	10-15	15-20		
440		15-20	20-30	30-40
510	10-15			
520	10-15	15-20		
620A	30-35	35-40		
640A		30-35	35-40	40-45
610	20-25			
620	20-25	25-35		
640		20-30	30-40	40-45
		(80m max. setting)		
720A	30-35			

Shaft lifts (mm) required for C Mk3 and RD F30A heads to give correct operating position of the rotor within the stator.

Pump Element	Depth of setting only - metres			
	0-60	60-120	120-180	180-240
640A		30-35	35-40	40-45
650A		30-35	35-40	40-45
640		20-30	30-40	40-45
720A	30-35	35-40		
740A		30-35	35-45	45-55
810	20-25			
820	20-25	25-35		
			(150m Max. setting)	
2521	35-40	40-50		
4011	35-40		(75m Max. setting)	

- (b) Raising the jack nut the prescribed distance should give the correct rotor operating position, however in some cases you may need to manually rotate pulley on pump by hand to feel least restriction and adjust the jack nut height accordingly.
- (c) When final lift correct position has been achieved, screw lock nut up and tighten against the jack nut. If the lock nut has grub screw location disregard screw as grub screw in lock nut can cause damage to main shaft thread.
- (d) Coat the jack nut, grub screws, lock nut threads and main shaft liberally with Kopre Cote to avoid corrosion and galling of threads.



WARNING: Do not start the Mono Borehole Pump, under any circumstances, until the final drive shaft has been cut to project not more than 1/8" to 1/2" above the top jack nut, otherwise damage and personal injury could endure.

See Page 30 for Operating Instructions.

Right Angle Drive Heads DR

Installation Instructions for DR Drive Heads Only

NOTE: The last length of column and shaft will only require one bobbin bearing assembly, the final connecting shaft should screw directly into a coupling nut fitted to the 5' shaft length.

Final Column and Shafting Installation (with element and column and shaft still held by column clamp).

Steps

1. (a) After installing the necessary column and shaft length, with the final column piece supported by the column clamp, fit the right angle drive mounting plate over the column socket.
(b) Fit the lifting tool to the column socket and lift the entire column and pipe assembly so that the upper most column socket is clear of the baseplate frame.
(c) Remove the column clamp and refit it above the right angle drive plate.
(d) Bolt down the baseplate to the baseplate frame.
(e) Rest the column clamp onto the baseplate, taking the entire weight of the pump column and shafting.
(f) Tightly screw the final connecting shaft into the last coupling nut.
2. With some shafting protruding, take a block of wood and gently tap the top of the shaft to knock it down. This will ensure the pump rotor has bottomed and located on the datum bar of the pump element.
3. Take the DR head, remove the housing cover and gasket. The jacking system support ring and associated fittings will be found in the installation kits provided. For the DR head this kit is DR 21KIT.
4. Take the DR head and separate the top and bottom sections of the head by removing the four bolts and spring washers.
5. Screw on the adaptor fitting to the column, then take stuffing box section and tightly screw it onto the column to head adaptor fitting. (Refer to appendix 1 for the correct final connection kit).
6. At this point you can now conveniently pack the gland with packing supplied.
NOTE:
 - (a) Ensure that each join of the gland packing piece is evenly offset approximately 1/2 turn from the next one.
 - (b) Use the gland follower to press each piece of packing into the gland.
 - (c) When gland packing is (4mm approx) from the top, place the gland follower plate in position and screw on nuts finger tight.
 - (d) The gland follower can be tightened after pump has run. The nuts should then be tightened firmly to allow for a slight weep. Excessive tightening causes shaft wear and excessive friction load on the prime mover/driver.
 - (e) Place the rubber thrower followed by the vee ring seal onto the shaft.
7. Take the top section of the head (with the housing cover removed) and -
 - (a) Install over final connecting shaft. The final connecting shaft should now protrude at least 50-100mm above head mainshaft.
 - (b) Replace the four bolts and nuts. To secure top and bottom head sections together, tighten bolts and spring washers securely.
8. (a) Attach a lifting sling around the head.
(b) Taking the weight of complete pump assembly on lifting gear, raise it sufficiently to remove the column clamp.
(c) Lower the complete assembly into place and secure the head onto the baseplate with bolts and nuts provided.
9. If necessary install the pulley on the main shaft and align it with the drive pulley.

Right Angle Drive Heads DR

10. (a) Install the jacking assembly by fitting the rotor thrust ring and the rotor support ring onto the protruding final connecting shaft.
- (b) Fix the rotor support ring to the final connecting shaft positioning it against the shaft or rotor thrust ring. Tighten the socket head screw to lock the support ring to the shaft.

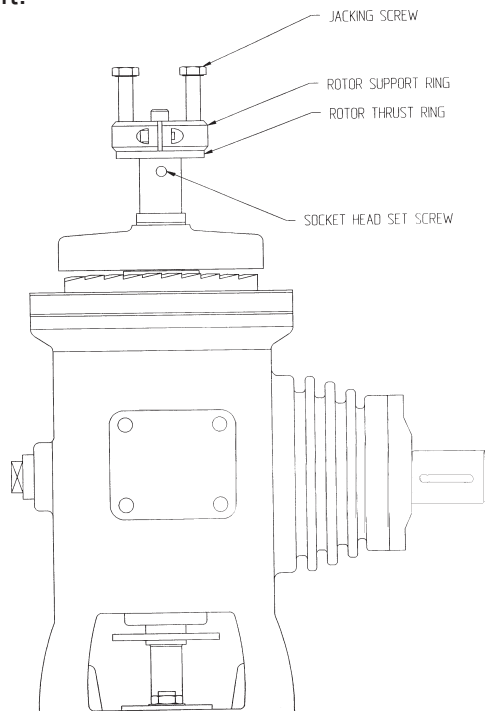

11. (a) Fit the two long M10 jacking screws into the rotor support ring.
- (b) Screw the jacking screws onto the rotor thrust ring.
- (c) Measure the distance between the rotor thrust ring and the bottom of the rotor support ring to determine the setting depth. (Refer to the table on page 22 for the required setting for your particular pump installation).

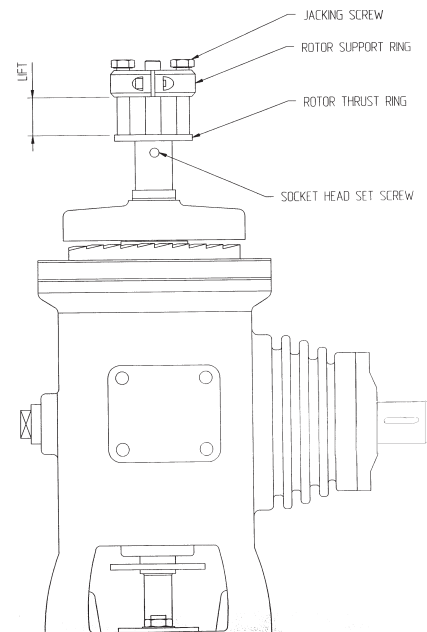

12. If the required height for setting the pump has been achieved, fit and tighten the socket set screws into the drive head main shaft, so as to lock the final connecting shaft to the main shaft.

NOTE: It is very important that the socket head set screws securing the final drive shaft are tightened correctly. Screw in each screw until they contact the drive shaft. Then progressively tighten the screws alternating from side to side.

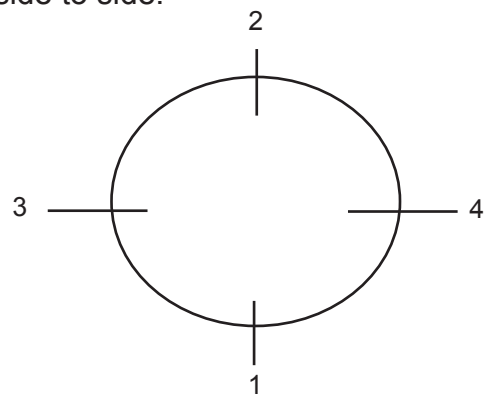

Failure to follow this procedure will result in excessive shaft runout at the gland packing. Excessive shaft runout (greater than 0.2mm) will result in poor gland packing life. After tightening the set screws remove the jacking screws and rotor thrust ring (if fitted). Reposition the rotor support ring against the top of the drive shaft and tighten the clamp bolt.

Right Angle Drive Heads DR

13. (a) If the required height for setting the pump has not been achieved, fit and tighten the socket set screws into the mainshaft so that they hold the final connection shaft securely.
- (b) Measure the distance lifted so far and record the final lift setting required.
- (c) Loosen the socket head cap screw of the rotor support ring. Unscrew the two jacking screws until the rotor support ring rests against the rotor thrust ring.
- (d) Tighten the rotor support ring securely to the final connecting shaft.
- (e) Screw the jacking screw down onto the rotor thrust ring until the rotor support ring is lifted the final setting amount, required for the full setting height of the pump.
- (f) Repeat step 12.

NOTE: Step 13 should not need to be repeated more than 2 times.

WARNING: Do not start the Mono Borehole Pump, under any circumstances, until the final drive shaft has been cut to project not more than the following distances above the end of the drive head main shaft.

NOTE: Sufficient final shaft should protrude to allow for lowering of the shaft/rotor arrangement onto the datum bar, when disassembly is required for maintenance.

REPEAT: Do not start the borehole pump until the final drive shaft has been cut.

14. Before turning the pump on, it is important to check the gease level in the drive head. This level should also be checked every 250 hours of running time. To fill, remove the filler/ level plug from the side of the housing. Use an Oil pump to fill to the base of the plug.
To change the grease, remove the gear inspection cover (Square plate held on by four screws) and using an oil pump remove as much oil as possible. The DR21 drive head will take approximately 1.6 Kg of grease to replace.
It is recommended to use a lithium base grease, which should not be mixed with other types of grease.
Recommended Grease:
UM 160 Li 0 EP
SHELL "TIVELAA" Grease

DRIVE HEAD	FINAL CONNECTION SHAFT PROTRUSION
DR21	75-80mm

Right Angle Drive RD-F30A

Installation Instructions for RD-F30A Drive Heads Only

NOTE: The last length of column and shaft will only require one bobbin bearing assembly, the final connecting shaft should screw directly into a coupling nut fitted to the 5' shaft length. Final Column and Shafting Installation (with element and column and shaft still held by column clamp).

Steps

1. (a) After installing the necessary column and shaft length, with the final column piece supported by the column clamp, fit the right angle drive mounting plate over the column socket.
- (b) Fit the lifting tool to the column socket and lift the entire column and pipe assembly so that the upper most column socket is clear of the baseplate frame.
- (c) Remove the column clamp and refit it above the right angle drive plate.
- (d) Bolt down the baseplate to the baseplate frame.
- (e) Rest the column clamp onto the baseplate, taking the entire weight of the pump column and shafting.
- (f) Tightly screw the final connecting shaft into the last coupling nut.

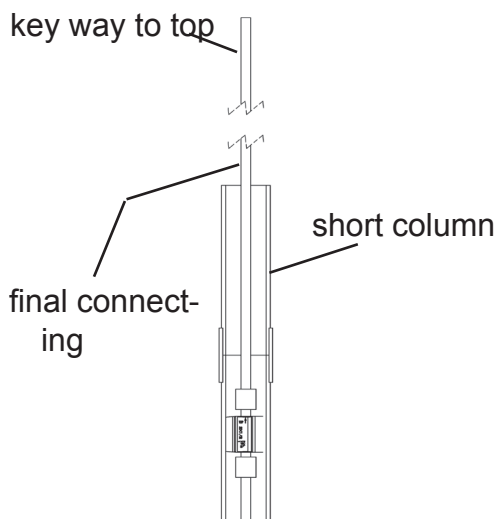

2. With the shafting protruding, take a block of wood and gently tap the top of the

shaft to knock it down. This will ensure the pump rotor has bottomed and located on the datum bar of the pump element.

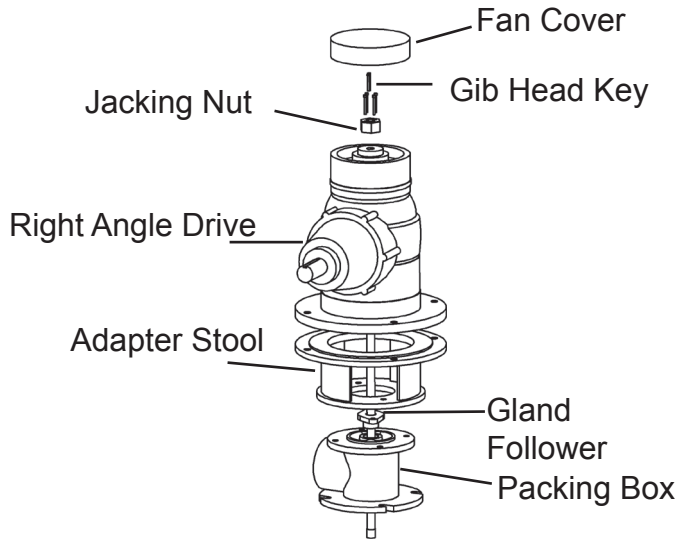

3. Before installing the RD-F30A drive head to the pump column it is important to make sure oil flows into the input shaft housing. To do this fill the main gear case to the correct level and tip the drive head forward until the input drive shaft hits the ground. The recommended Oils for this drive head are as below. To fill the drive head this requires approximately 1.5 litres of oil.

For areas with ambient temperatures between 0 degrees and 30 degrees celsius use

Brand	Type
B.P.	GRXP 220
Caltex	GR & O
Mobil	630
Esso	Terresso 850
Shell	Omala 220

For areas with ambient temperatures between 30 degrees and 60 degrees celsius use

Brand	Type
B.P.	GRXP 220
Caltex	GR & O
Mobil	632
Esso	Terresso 100
Shell	Omala 220
Ampol	Gearlube SP 220
Castrol	Alpha SP 220

Right Angle Drive RD-F30A

3. Take the RD-F30A head, remove the fan cover.
4. Take the RD-F30A head and remove the packing box by removing the four bolts and spring washers.
5. Screw on the adaptor fitting to the column, then take stuffing box section and tightly screw it onto the column to head adaptor fitting. (Refer to appendix 1 for the correct final connection kit).
6. At this point you can now conveniently pack the gland with packing supplied.

NOTE:

- (a) Ensure that each join of the gland packing piece is evenly offset approximately 1/2 turn from the next one.
 - (b) Use the gland follower to press each piece of packing into the gland.
 - (c) When gland packing is (4mm approx) from the top, place the gland follower plate in position and screw on nuts finger tight.
 - (d) The gland follower can be tightened after pump has run. The nuts should then be tightened firmly to allow for a slight weep. Excessive tightening causes shaft wear and excessive friction load on the prime mover/driver.
 - (e) Place the rubber thrower followed by the vee ring seal onto the shaft.
7. Take the top section of the head (with the housing cover removed) and -
 - (a) Install over final connecting shaft. The final connecting shaft should now protrude at least 50-100mm above head mainshaft.
 - (b) Replace the four bolts and nuts. To secure top and bottom head sections together, tighten bolts and spring washers securely.
 8. (a) Attach a lifting sling around the head.
(b) Taking the weight of complete pump assembly on lifting gear, raise it sufficiently to remove the column clamp.

(c) Lower the complete assembly into place and secure the head onto the baseplate with bolts and nuts provided.

9. If necessary install the pulley on the main shaft and align it with the drive pulley.
10. Add the Gib head key to key-way in the final connecting shaft, and fit in top of the clutch
11. Screw the jacking nut onto the clutch to determine the setting depth. Mark this point on the thread of the final connecting shaft.

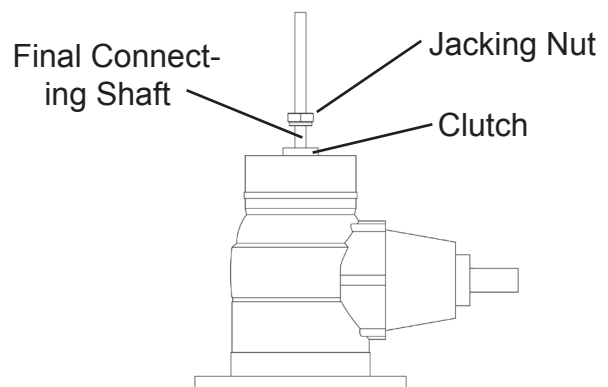

12. Lift the shafting by tightening the jacking nut. Lift the shafting to the correct depth setting (Refer to the table on page 22 for the required setting for your particular pump installation).
13. If the required height for setting the pump has been achieved, fit and tighten the socket set screws into the jacking head, so as to lock the final connecting shaft to the main shaft.

WARNING: Do not start the Mono Borehole Pump, under any circumstances, until the final drive shaft has been cut to project not more than the following distances above the end of the drive head main shaft.

NOTE: Sufficient final shaft should protrude to allow for lowering of the shaft/rotor arrangement onto the datum bar, when disassembly is required for maintenance.

REPEAT: Do not start the borehole pump until the final drive shaft has been cut.

Right Angle Drive Pulley Set-up

Right Angle Drives Pulley and Belt Set-up

The belt tension is to be set as per the belt manufactures specification. Over tensioning the belt will put extra load on the drive head and motor bearings, thus reducing the life of the unit.

The diagrams below show the key criteria to setting up the pulleys.

Shafts are parallel, but out of alignment

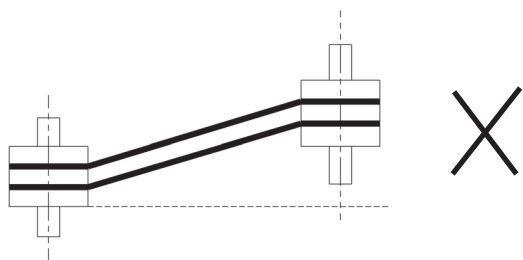

Shafts are not parallel to each other

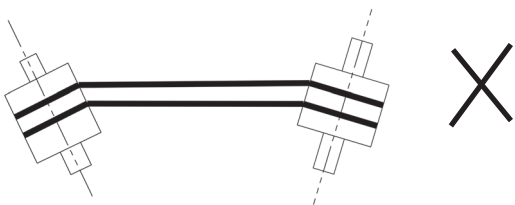

Correct Alignment

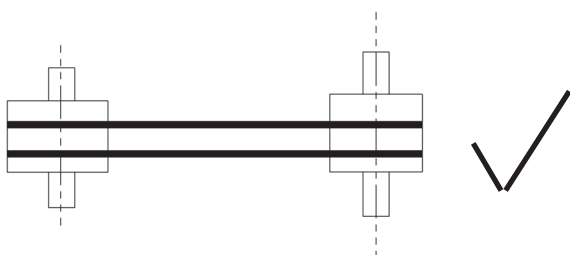

To add or remove V Belts never use levers. To prevent damage to the V Belts, always install by adjusting the motor position. The motor position is adjusted by moving the motor on the base plate rails, as shown below.

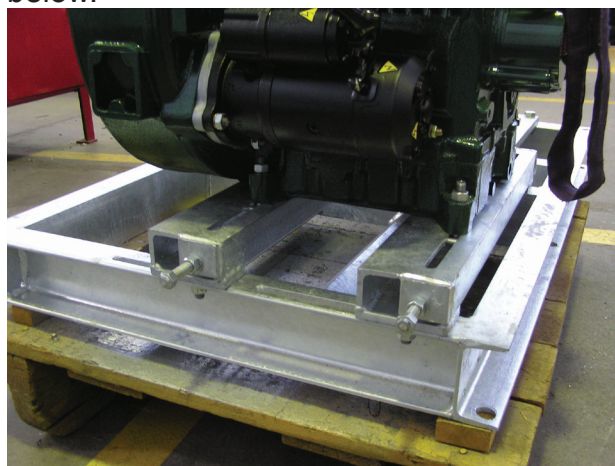

The photo graph below shows a typical right angle drive set up (guard removed for clarity). Note: Guard must be installed prior to operation.



Operating Instructions

Operating Instructions

Steps

(1) Your pump installation is now complete. Before replacing vee belts and drive guard, check that the direction of rotation from the motor or engine via the belts will be anti-clockwise when viewed from the end of the drive shaft.

NOTE: For right angle drive heads only, refit the housing cover and check to see if the final connection shaft, that is protruding, is not touching the cap, before starting the pump.

(2) If an engine driver is used either a manual or centrifugal (automatic clutch) must be used to allow the motor to build up speed before engaging.

(3) The bore must be properly developed before delivering water into a reticulation system. Usually two hours running will ensure sand and silt are removed and the water will be clear. Do not stop the pump if the water is sandy or dirty: sand will settle and you will not be able to restart the pump.

(4) If air is pumped at any time after normal startup, the bore is being over-

pumped (forked). Reduce pump speed either by slowing the engine or changing pulley sizes for a motor until air is no longer present.

- (5) If you intend to pump against -
(a) high surface discharge head
(b) a pressure system

A non-return valve must be fitted to the discharge line.

- (6) The Mono borehole pump is a positive displacement unit. For high heads or long lines it is suggested that either -

- (a) hand operated by-pass valve, or
(b) relief valve set to 10% above the maximum surface discharge pressure be fitted.

WARNING: Ensure that all valves are set open and locked before starting the pump.

See sketches below.

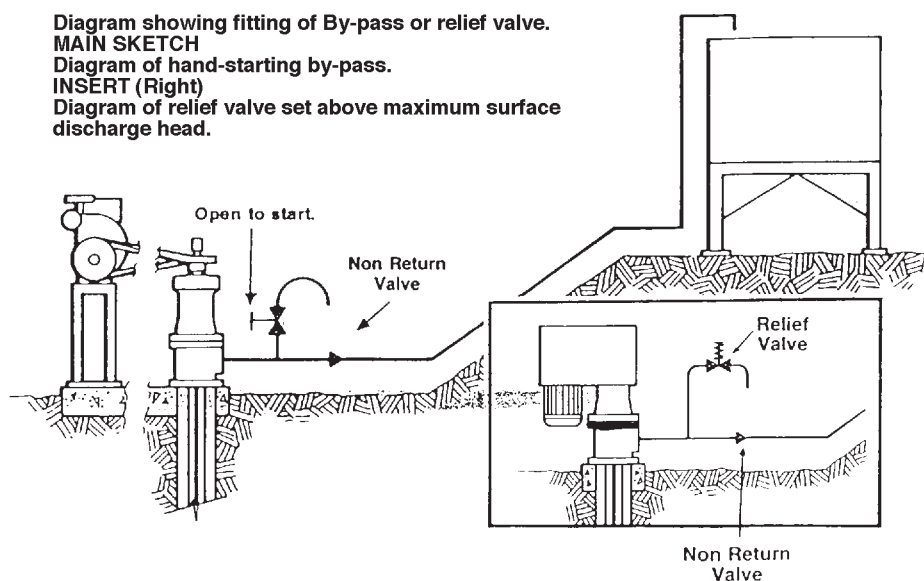

Maintenance

Pump Maintenance and Service Requirements

Because of its simplicity of design, and the fact that rotating underground parts and bearings are water and self-lubricated, the underground section of your installation should require little attention or replacement, unless you are pumping particularly corrosive or abrasive water.

NOTE: If the water is known to be corrosive (ie, it has a low pH value, or high conductivity value) a water analysis should be obtained to ensure that correct pump materials are selected for your installation. This will ensure a longer, maintenance free life.

1. Packed Glands

The gland should be inspected and adjusted regularly to provide the correct lubrication with a slight leakage. The gland packing should be replaced approximately every 5,000 hours, or sooner if the gland shows signs of excessive leakage. Grease gland bolts and nuts at each inspection.

2. Bearings

Bearings are rated for operation in excess of 10,000 hours. However wear will occur quickly if bearings are allowed to operate without lubrication or under dirty conditions, or if overloaded due to excessive belt tension. See Table 1.

3. Open Cage Bearings

Check every 5,000 hours. Wash thoroughly with solvent. Repack with high speed ball bearing grease. Sealed bearings require no attention.

4. Belt Tension

Belt tension should be checked during gland inspections. If belts need replacement, replace ALL belts with a matched set.

Underground Components

1. Pump Element

As the pumping element is water-lubricated, it should not require service. However if service or replacements become necessary, the work can be carried out on the site without special tools.

Care should be taken not to damage the surface finish of the flexible drive shaft (Part No. 2600). Never use stilsons or tightening tools on the flexible shaft during service.

2. Column, Driveshaft, Bobbin Bearings

Need for replacement of any worn or defective units will be obvious from visual inspection, but as withdrawal of column and driveshaft assemblies, and the pumping elements, requires time and effort it is wise always to replace any items which are suspect.

3. Pump Stator

The stator is natural rubber moulded inside a metal tube, and **should not** be lubricated with any petroleum based products (i.e., hand cleaner, grease etc.).

Stators to be fitted with suction end (marked on stator) towards the foot valve.

Right Angle Drive Heads DR and RD F30A

DR AND RD F30A DRIVE HEAD MAINTENANCE SCHEDULE			
MAINTENANCE CHECKS	SERVICE PERIOD BASED ON 8HR DAY 7DAY WEEK OPERATION	SERVICE PERIOD RUNNING HOURS	SERVICE PERIOD SPECIFIC DETAILS
Check gland packing and re-tighten as required	4 months	1,000	
Replace gland packing	20 months	5,000	
Grease gland bolts and inspect pump	4 months	1,000	
Inspect pulley and belt condition	4 months	1,000	
Replace belts	12 months	3,000	
Check pressure gauge and record DP	4 months	1,000	
Overhaul drive head	12 months	3,000	
Re-pack with grease	12 months	3,000	
Refill with Recommended Oil (RD 30A Only)	12 months	3,000	
(refer to page 27 for recommended oil)			

Appendix

Borehole Adapter Kits		
Pump Element to Column and Drive Shaft		
PART NO.	COLUMN SIZE	PUMP ELEMENT
BH-KIT61	1 1/2" x 1/2"	310
BH-KIT62	1 1/2" x 1/2"	320, 306
BH-KIT63	1 1/2" x 1/2"	420, 510
BH-KIT64	2" x 1/2"	440, 610
BH-KIT65	2" x 5/8"	520, 620
BH-KIT66	2" x 5/8"	620A, 640A
BH-KIT67	2 1/2" x 3/4"	640, 640A, 650A
BH-KIT69	3" x 7/8"	720A, 810, 820
BH-KIT70	4" x 7/8"	810, 820, 2521, 4011
BH-KIT71	2" x 1/2"	620A
BH-KIT73	2 1/2" x 3/4"	620
BH-KIT74	2" x 1/2"	520, 620
BH-KIT74	2" x 5/8"	420, 440, 510, 610
BH-KIT75	2 1/2" x 3/4"	720A, 740A
BH-KIT76	3" x 7/8"	720A, 740A

Europe

Mono Pumps Ltd, Martin Street, Audenshaw
Manchester, M34 5JA, England
T. +44 161 339 9000
E. info@mono-pumps.com

D.M.I EST, 56, rue du Pont
88300 Rebeuville, France
T. +33 3 29 94 26 88
E. dmi-est@dmi-est.fr

Americas

Monoflo Inc., 10529 Fisher Road
Houston, Texas 77041, USA
T. +1 713 980 8400
E. inquire@monoflo.com

Monoflo S.A., Ing Huergo 2239
(1842) Monte Grande
Pcia. de Buenos Aires, Argentina
T. +54 11 4290 9940/50
E. info@monoflo.com.ar

Monoflo Canada, 6010 – 53rd Ave
Alberta, Lloydminster
T9V2T2, Canada
T: + 1 780 875 5584
E: info@monoflo.com.ar

Asia

Mono Pumps Ltd, No. 500 YaGang Road
Lujia Village, Malu, Jiading District
Shanghai 201801, P.R. China
T. +86 21 5915 7168
E. monoshanghai@nov.com

Australasia

Mono Pumps (Australia) Pty Ltd
338-348 Lower Dandenong Road
Mordialloc, Victoria 3195, Australia
T. 1800 333 138
E. ozsales@monopumps.com

Mono Pumps (New Zealand) Ltd
35-41 Fremlin Place, Avondale
Auckland, 1026, New Zealand
T. +64 9 829 0333
E. info@monopumps.co.nz

Melbourne	T.	03 8587 4303	F.	03 8587 4388
Sydney	T.	02 8536 0900	F.	02 9542 3649
Brisbane	T.	07 3350 4582	F.	07 3350 3750
Adelaide	T.	08 8447 8333	F.	08 8447 8373
Perth	T.	08 9479 0444	F.	08 9479 0400
Darwin	T.	08 8931 3300	F.	08 8931 3200
Kalgoorlie	T.	08 9022 4880	F.	08 9022 3660
Christchurch NZ	T.	+64 3 341 8379	F.	+64 3 341 8486

www.monopumps.com



© Mono Pumps Limited November 2009 Literature reference: MPA554-8

Mono® is a registered trademark of Mono Pumps Limited. seepex® is a registered trademark of seepex Seeberger GmbH + Co. NEMO®, NM® and NE® are registered trademarks of Erich Netzsch GmbH & Co Holding KG. NETZSCH® is a registered trademark of NETZSCH Mohnpumpen GmbH. Mono Pumps Limited is not an authorised distributor of parts and services for the products of Seeberger GmbH, Allweiler, NETZSCH Mohnpumpen GmbH, PCM, Robbins & Myers or Orbit and Mono Pumps Limited products are not associated with, endorsed by, or sponsored or manufactured by these companies.

 **Mono®**

One Company, Unlimited Solutions